



Raycap

RayDat Narrow
Data & Signal Line
System Protection

C A T A L O G

About Raycap

Raycap was founded in 1987 with a vision of creating and providing solutions that protect the world's infrastructure. From telecommunications to new traditional energy networks, and from transportation systems to industrial applications of all types, Raycap is there with solutions to ensure equipment uptime in spite of harsh electrical environments. The company strives to keep its customers' sophisticated, mission-critical equipment running seamlessly and continuously, and is driven to make ongoing advancements in its surge protection technologies and product offerings.



Table of Contents

	RayDat Narrow Modular Features	3
	Naming Convention	4
	ANALOG SYSTEMS	
	Signal Line Systems	5
	RayDat NSL-2 LF	6
	RayDat NSL-2	8
	Single Pair Systems	11
	RayDat NSP-2 LF	12
	RayDat NSP-2	14
	DIGITAL SYSTEMS	
	Bus Systems	17
	RayDat NSB-3 LF	18
	RayDat NSB-3	20
	DC POWER SYSTEMS	
	DC Power Systems in Signaling Applications	23
	RayDat NPS-2	24
	ACCESSORIES	
	RayDat Monitoring Unit Transmitter & Receiver	27
	RayDat NMU Set	28
	Product Index & Legacy Product Names	31

RayDat Narrow Modular Features

RayDat surge protection for data and signal line systems provides unsurpassed electrical protection for signal power applications. These products meet the diverse requirements of industrial and commercial signal protection applications. RayDat products are available in a variety of operating voltages and configurations that conform to the latest industry standards and certifications.

- All SPDs can be monitored remotely for alarm/defect messages
- Products may be manually disconnected, and their signals monitored/measured in the field or the control room
- Each quick connect terminal has its own measurement point
- The grounding clip enables surge dissipation to the ground and provides a secure connection to the DIN Rail
- No tools are required for assembly
- If the fine SPD protection elements (Diodes) become defective, protection remains in place via basic Gas Discharge Tube protection
- Low damping enables usage for longer distances

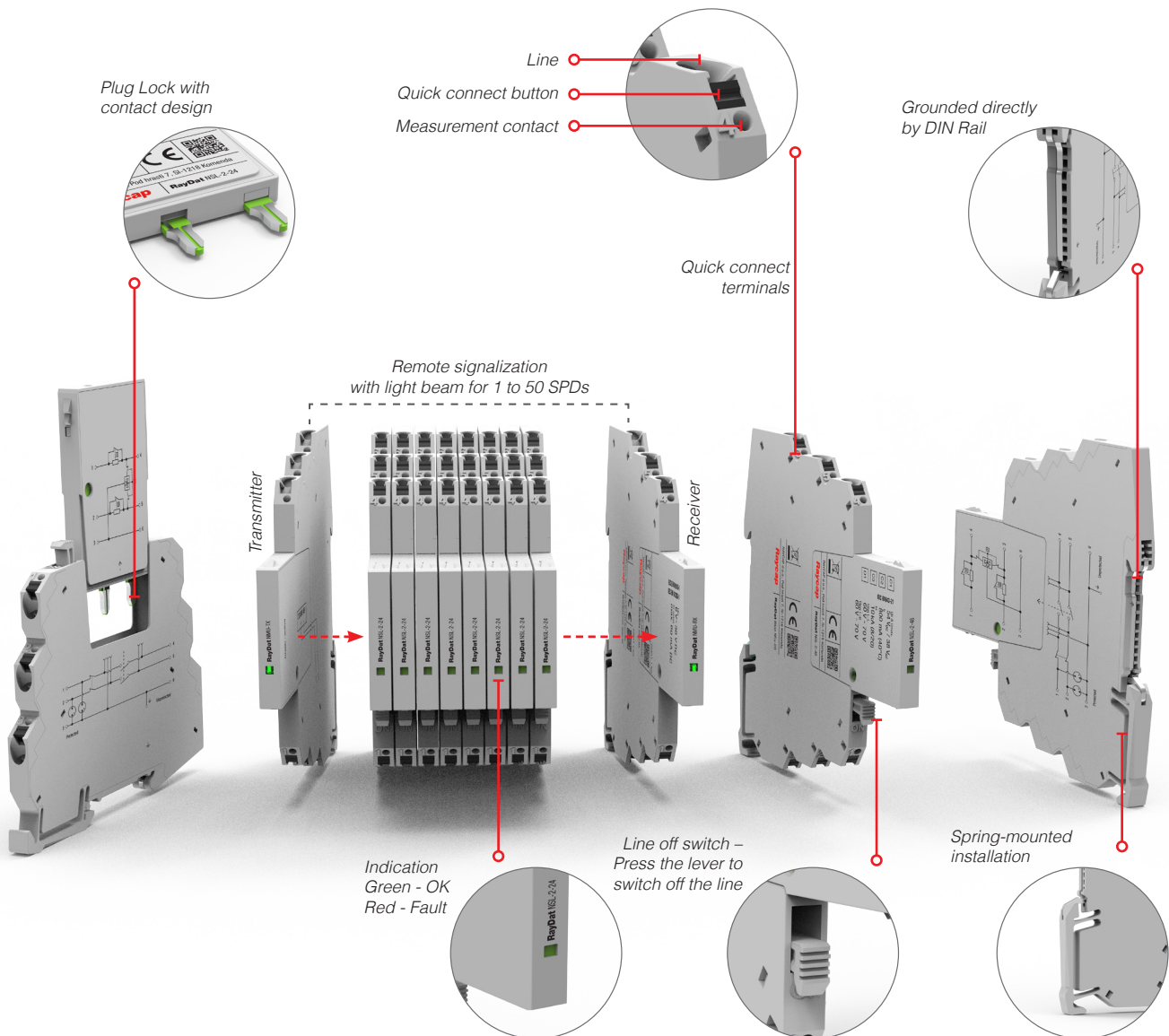



Naming Convention

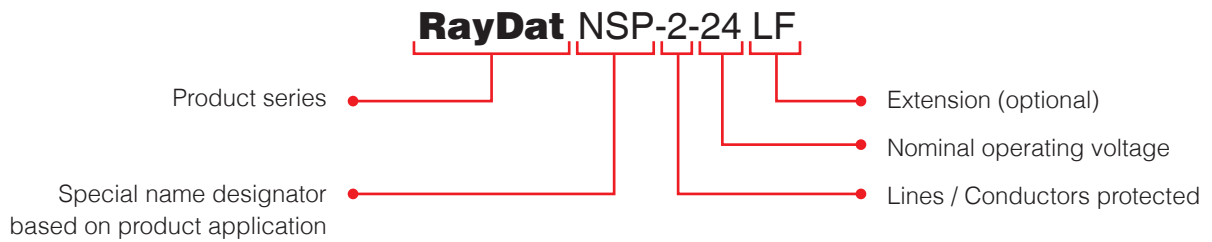

- NSL** Narrow Signal protection for Lines with high surge capability
- NSP** Narrow Signal protection for Pairs with high surge capability
- NSP/0** Version with '0' ohm resistance
- NPS** Narrow Power Supply protection used with signal systems
- NSB** Narrow Signal protection for Bus systems with high surge capability

- NMU** Narrow Monitoring Unit

- TX** Monitoring Unit Transmitter
- RX** Monitoring Unit Receiver
- M** Extension for Module
- LF** Low Frequency product version

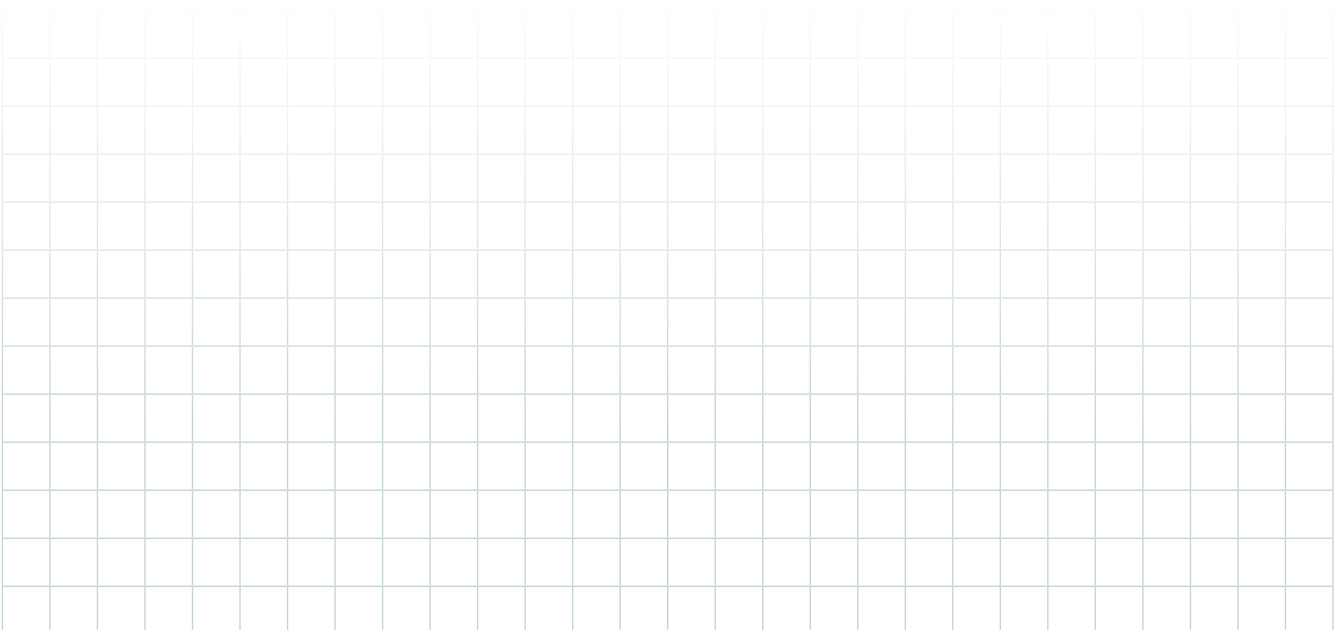

Modular Surge Protective Devices (SPDs) for Data & Signal Lines



Signal Line Systems

RayDat NSL-2 LF Series
RayDat NSL-2 Series

Special features:

- Narrow form factor - just 6.2 mm wide
- Very high surge ratings
- Different shield-handling options available
- The connection lines remain enabled during module replacement (hot swapping)
- Equipped with quick connect terminals for fast wiring

Application:

- Signals and communication circuits which could be isolated from ground

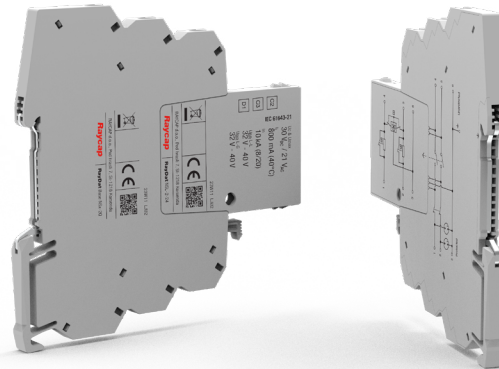

Raycap offers surge protectors for a variety of analog signal lines. In industrial operations, analog signals are used in control systems for sensing and measurement purposes.

These efficient overvoltage barriers contain both coarse and fine protection stages, and provide longitudinal and a transverse surge protection.

Sensors such as temperature sensors, pressure sensors, level sensors, and position sensors generate analog signals that provide continuous and precise information about the physical parameters being measured.

Due to their internal configuration, RayDat analog signal protection products can also protect high-frequency signals.

Modular SPD for Single Pair

RayDat NSL-2 LF Series

D1 • C1 • C2 • C3



IEC/EN Category: D1/C1/C2/C3
 Voltages: 5, 12, 24V DC
 Frequency Range: up to 1MHz
 Housing: Modular Design
 Compliance: IEC/EN 61643-21
 UL 497B 4th Edition

Configuration:

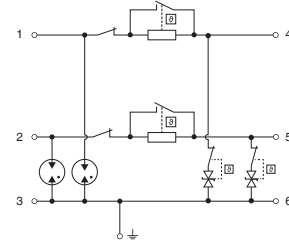

Technical Data

RayDat NSL-2-xx LF Series

5

12

24

Electrical

Lines Protected			5	12	24
Lines Protected				1 (2 Conductors)	
Nominal Operating Voltage (DC)	U_n		5V	12V	24V
Maximum Continuous Operating Voltage (DC)	U_c		8.5V	15V	30V
Rated Load Current at 40 °C	I_L			800 mA	
Rated Load Current at 70 °C	I_L			600 mA	
C2 Nominal Discharge Current (8/20 μ s)	(Line-Line) I_n			10 kA	
	(Line-Ground)			10 kA	
C2 Total Nominal Discharge Current (8/20 μ s)	I_n			20 kA	
C2 Voltage Protection Level (10kV/5kA)	(Line-Line) U_p		80V	100V	160V
	(Line-Ground)		100V	110V	140V
C3 Voltage Protection Level (1 kV/ μ s)	(Line-Line) U_p		48V	60V	120V
	(Line-Ground)		24V	30V	60V
D1 Impulse Current (10/350 μ s)	(Line-Line) I_{imp}			2.5 kA	
	(Line-Ground)			2.5 kA	
D1 Total Impulse Current (10/350 μ s)	I_{imp}			5 kA	
Rated Spark Overvoltage	(Line-Line)		18V - 46V	32V - 62V	66V - 98V
	(Line-Ground)		9V - 23V	16V - 31V	33V - 49V
Response Time Overvoltage Protection	t_A			< 1 ns	
Thermal Protection				Yes	
Insulation Resistance of the Protection	(Line-Line) R_{iso}		> 340 k Ω	> 7.5 M Ω	> 15 M Ω
Serial Resistance per Path	R			1 Ω	
Capacitance	(Line-Line) C		typ. 5 nF	typ. 3 nF	typ. 1.5 nF
	(Line-Ground)		typ. 10 nF	typ. 6 nF	typ. 3 nF
Maximum Frequency	f_G		250 kHz	500 kHz	1 MHz

Mechanical

Temperature Range		-40 °F to +176 °F [-40 °C to +80 °C]
Conductor Cross Section (max.)		12 AWG / 4 mm ² (solid) 14 AWG / 2.5 mm ² (flexible)
Degree of Protection IEC/EN 60529		IP20 (built-in)
Housing Material		Thermoplastic; Grey; Extinguishing Degree V-0
Mounting IEC/EN 60715		35 mm DIN Rail
Operating State / Fault Indication		Green Flag / Red Flag

Order Information

Order Code	5	12	24
NSL-2-xx LF	7088.32	7088.34	7088.36
NSL-2-xxM LF (module)	7088.33	7088.35	7088.37

RayDat NSL-2 LF Series

Configuration

Legend

- DB Diode Block
- GDT Gas Discharge Tube
- PG Protective Grounding
- R Resistor

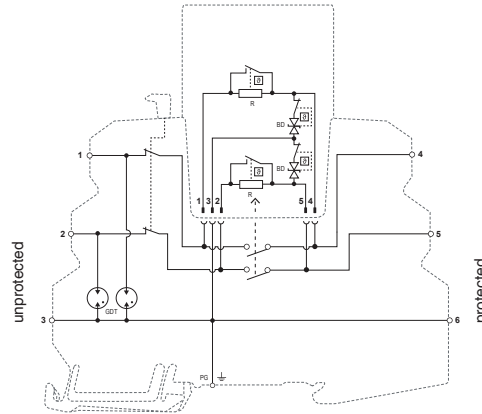

Dimensions & Packaging

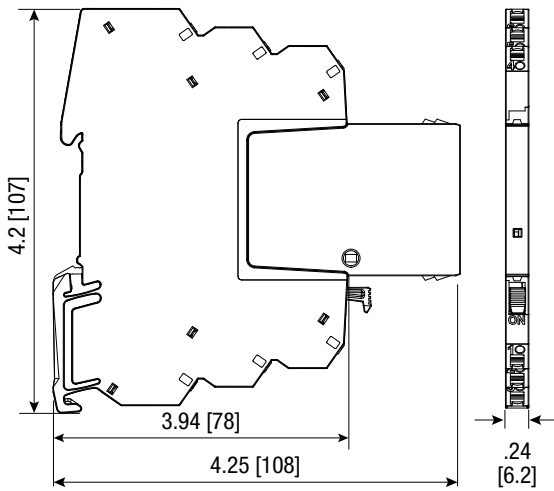

NSL-2-xx LF Series	5	12	24
Dimensions			
Weight per Unit	2.12 oz [60g]		
Dimensions DIN 43880	.24" [6.2mm]		
Packaging Dimensions (Single Unit)	4.45×4.37×0.43" [113×111×11 mm]		
Minimum Package Quantity	15 pieces		

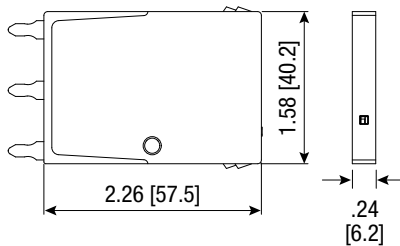

NSL-2-xxxM LF Series	5	12	24
Dimensions			
Weight per Unit	0.56 oz [16g]		
Packaging Dimensions (Single Unit)	4.45×4.37×0.43" [113×111×11 mm]		
Minimum Package Quantity	15 pieces		

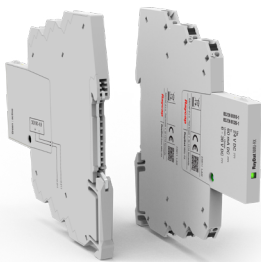

Monitoring Unit
Transmitter
& Receiver
available for all
product variants.

inches
[mm]



Modular SPD for Single Pair

RayDat NSL-2 Series

D1 • C1 • C2 • C3

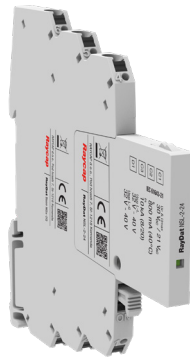

IEC/EN Category: D1/C1/C2/C3
 Voltages: 5, 12, 24, 48V DC
 Frequency Range: 120 MHz
 Housing: Modular Design
 Compliance: IEC/EN 61643-21
 UL 497B 4th Edition

Configuration:

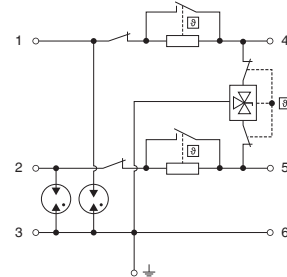

Technical Data

RayDat NSL-2-xx Series

		5	12	24	48
Electrical					
Lines Protected		1 (2 Conductors)			
Nominal Operating Voltage (DC)	U_n	5V	12V	24V	48V
Maximum Continuous Operating Voltage (DC)	U_c	8.5V	15V	30V	54V
Rated Load Current at 40 °C	I_L	800 mA			
Rated Load Current at 70 °C	I_L	600 mA			
C2 Nominal Discharge Current (8/20 μ s)	(Line-Line) I_n	10 kA			
	(Line-Ground)	10 kA			
C2 Total Nominal Discharge Current (8/20 μ s)	I_n	20 kA			
C2 Voltage Protection Level (10kV/5kA)	(Line-Line) U_p	140V	150V	170V	210V
	(Line-Ground)	260V	270V	290V	300V
C3 Voltage Protection Level (1 kV/ μ s)	(Line-Line) U_p	24V	36V	70V	130V
	(Line-Ground)	24V	36V	70V	130V
D1 Impulse Current (10/350 μ s)	(Line-Line) I_{imp}	2.5 kA			
	(Line-Ground)	2.5 kA			
D1 Total Impulse Current (10/350 μ s)	I_{imp}	5 kA			
Rated Spark Overvoltage	(Line-Line)	9V-25V	16V-33V	33V-51V	60V-81V
	(Line-Ground)	9V-25V	16V-33V	33V-51V	60V-81V
Response Time Overvoltage Protection	t_A	< 1 ns			
Thermal Protection		Yes			
Insulation Resistance of the Protection	(Line-Line) R_{iso}	> 170 k Ω	> 7.5 M Ω	> 15 M Ω	> 27 M Ω
Serial Resistance per Path	R	1 Ω			
Capacitance	(Line-Line) C	typ. 25 pF			
	(Line-Ground)	typ. 20 pF			
Maximum Frequency	f_G	120 MHz			
Mechanical					
Temperature Range		-40 °F to +176 °F [-40 °C to +80 °C]			
Conductor Cross Section (max.)		12 AWG / 4 mm ² (solid)			
		14 AWG / 2.5 mm ² (flexible)			
Degree of Protection IEC/EN 60529		IP20 (built-in)			
Housing Material		Thermoplastic; Grey; Extinguishing Degree V-0			
Mounting IEC/EN 60715		35 mm DIN Rail			
Operating State / Fault Indication		Green Flag / Red Flag			
Order Information					
Order Code		5	12	24	48
NSL-2-xx		7088.26	7088.28	7088.01	7088.30
NSL-2-xxM (module)		7088.27	7088.29	7088.02	7088.31

RayDat NSL-2 Series

Configuration

Legend

- DB Diode Block
- GDT Gas Discharge Tube
- PG Protective Grounding
- R Resistor

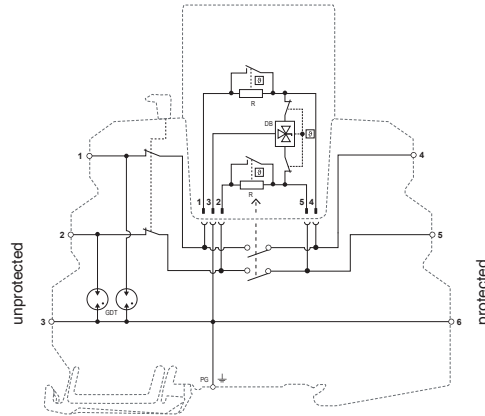

Dimensions & Packaging

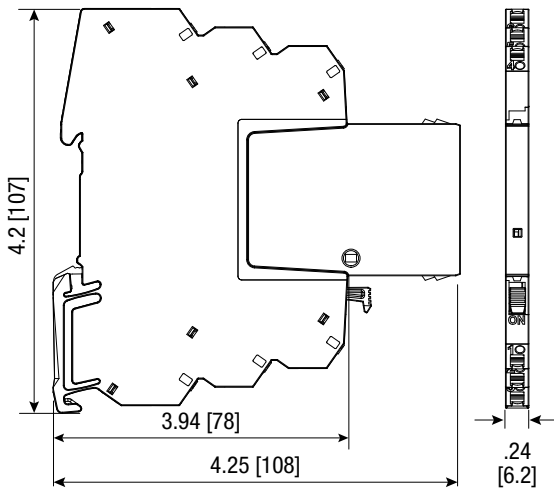

NSL-2-xx Series	5	12	24	48
Dimensions				
Weight per Unit	2.12 oz [60g]			
Dimensions DIN 43880	.24" [6.2mm]			
Packaging Dimensions (Single Unit)	4.45×4.37×0.43" [113×111×11 mm]			
Minimum Package Quantity	15 pieces			

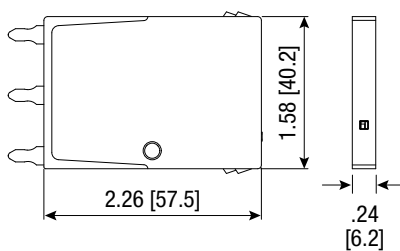

NSL-2-xxxM Series	5	12	24	48
Dimensions				
Weight per Unit	0.56 oz [16g]			
Packaging Dimensions (Single Unit)	4.45×4.37×0.43" [113×111×11 mm]			
Minimum Package Quantity	15 pieces			

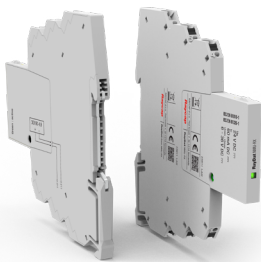

Monitoring Unit
Transmitter
& Receiver
available for all
product variants.

inches
[mm]



Notes

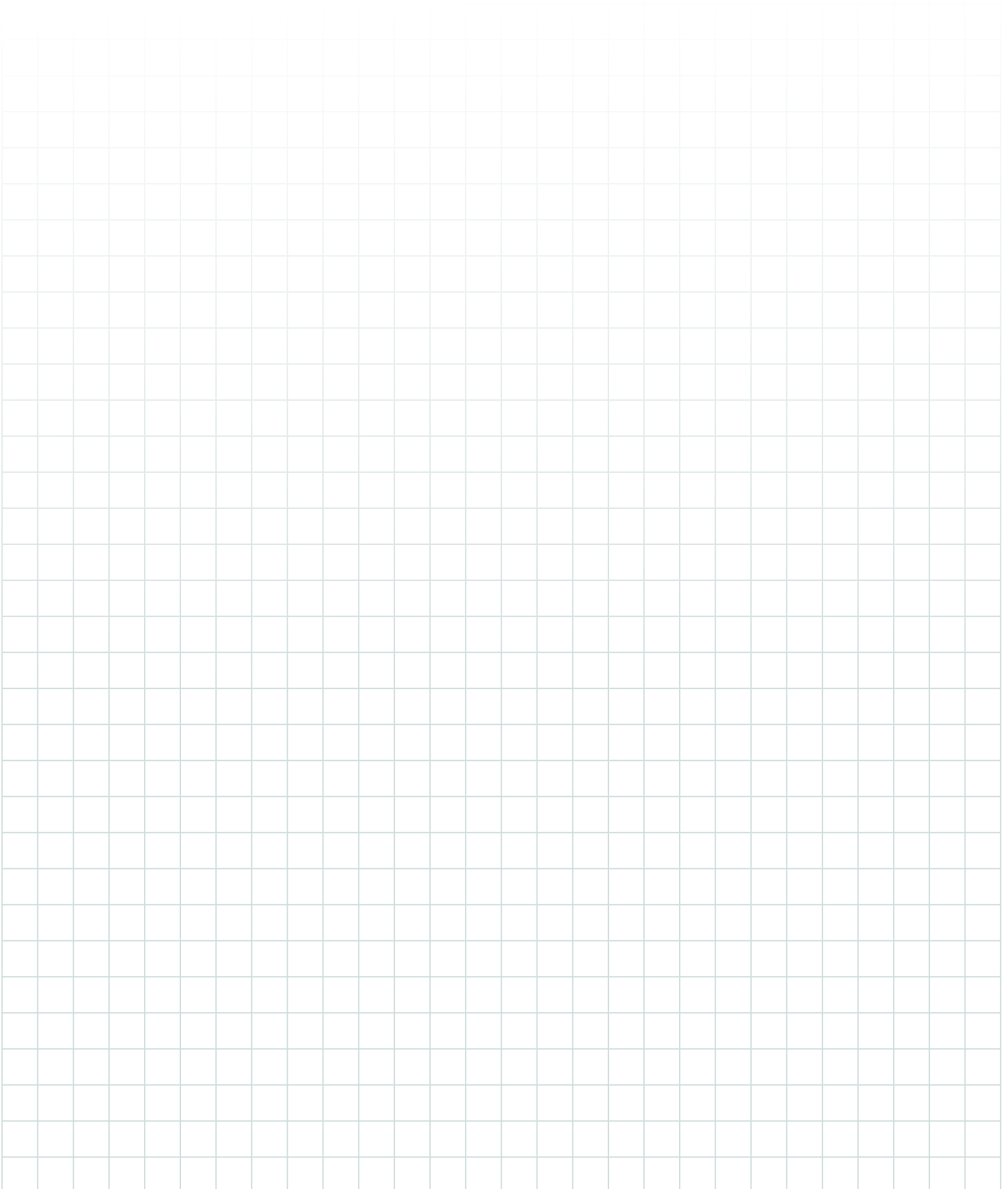

Modular Surge Protective Devices (SPDs) for Single Pair Systems



Single Pair Systems

RayDat NSP-2 LF Series
RayDat NSP-2 Series

Special features:

- Narrow form factor - just 6.2 mm wide
- Very high surge ratings
- Different shield-handling options available
- The connection lines remain enabled during module replacement (hot swapping)
- Equipped with quick connect terminals for fast wiring

Application:

- Current loops

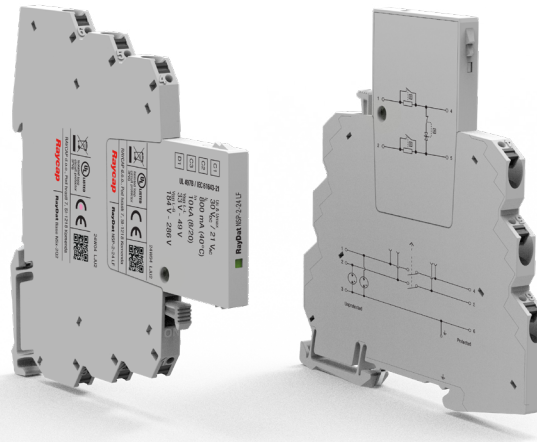

Raycap offers surge protectors for a variety of analog signal lines. In industrial operations, analog signals are used in control systems for sensing and measurement purposes.

The RayDat SP Series of surge protective devices has been developed to protect a pair loop, which could be ungrounded onto data, signal and communication circuits. It is intended for those applications where high ground potential rises may frequently occur, such as locations close to electric railways. Sensors such as temperature sensors,

pressure sensors, level sensors, and position sensors generate analog signals that provide continuous and precise information about the physical parameters being measured.

Due to their internal configuration, RayDat analog signal protection products can also protect high-frequency signals.

inches
[mm]

Modular Low Frequency SPD for Single Pair

RayDat NSP-2 LF Series

D1 • C1 • C2 • C3



IEC/EN Category: D1/C1/C2/C3

Voltages: 24, 24/0 V DC

Frequency Range: 1.5 MHz

Housing: Modular Design

Compliance: IEC/EN 61643-21, UL 497B 4th Edition

Configuration:

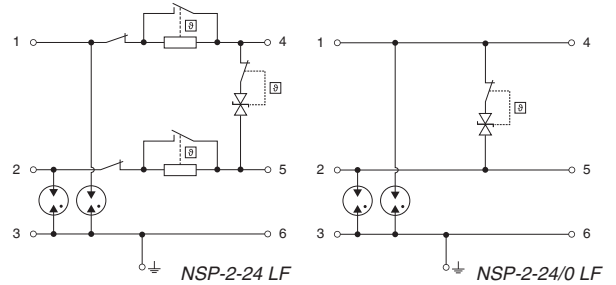

24

24/0

Technical Data

NSP-2 LF Series

Electrical

		1 (2 Conductors)	
Lines Protected			
Nominal Operating Voltage (DC)	U_n	24V	24V
Maximum Continuous Operating Voltage (DC)	U_c	30V	30V
Rated Load Current at 40 °C	I_L	800 mA	12 A
Rated Load Current at 70 °C	I_L	600 mA	10 A
C2 Nominal Discharge Current (8/20 μ s)	(Line-Line) I_n	10 kA	250 A
	(Line-Ground)		10 kA
C2 Total Nominal Discharge Current (8/20 μ s)	I_n		20 kA
C2 Voltage Protection Level (10kV/5kA)	(Line-Line) U_p	140V	-
	(Line-Ground)	950V	950V
C3 Voltage Protection Level (1 kV/ μ s)	(Line-Line) U_p	60V	60V
	(Line-Ground)		650V
D1 Impulse Current (10/350 μ s)	(Line-Line) I_{imp}		2.5 kA
	(Line-Ground)		2.5 kA
D1 Total Impulse Current (10/350 μ s)	I_{imp}		5 kA
Rated Spark Overvoltage	(Line-Line)	33V - 49V	33V - 51V
	(Line-Ground)	184V - 286V	184V - 286V
Response Time Overvoltage Protection	t_A		< 1 ns
Thermal Protection			Yes
Insulation Resistance of the Protection	(Line-Line) R_{iso}		> 15 M Ω
Serial Resistance per Path	R	1 Ω	0.1 Ω
Capacitance	(Line-Line) C	typ. 1 nF	typ. 1 nF
	(Line-Ground)		typ. 15 pF
Maximum Frequency	f_G		1.5 MHz

Mechanical

Temperature Range	-40 °F to +176 °F [-40 °C to +80 °C]
Conductor Cross Section (max.)	12 AWG / 4 mm ² (solid)
	14 AWG / 2.5 mm ² (flexible)
Degree of Protection IEC/EN 60529	IP20 (built-in)
Housing Material	Thermoplastic; Grey; Extinguishing Degree V-0
Mounting IEC/EN 60715	35 mm DIN Rail
Operating State / Fault Indication	Green Flag / Red Flag

Order Information

Order Code	24	24/0
NSP-2-xx LF	7088.03	7088.60
NSL-2-xxM LF (module)	7088.04	7088.61

RayDat NSP-2 LF Series

Configuration

Legend

- BD Bi-directional TVS Diode
- GDT Gas Discharge Tube
- PG Protective Grounding
- R Resistor

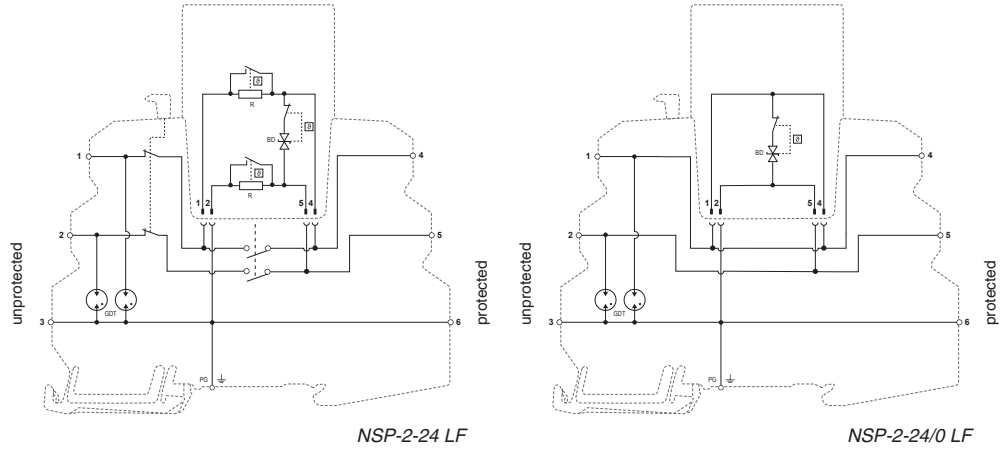

Dimensions & Packaging

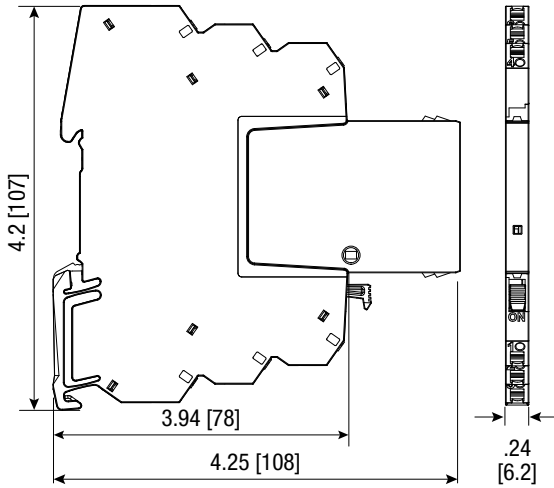

NSP-2 LF Series	24	24/0
Dimensions		
Weight per Unit	2.12 oz [60g]	2.05 oz [58g]
Dimensions DIN 43880	.24" [6.2 mm]	
Packaging Dimensions (Single Unit)	4.45×4.37×0.43" [113×111×11 mm]	
Minimum Package Quantity	15 pieces	

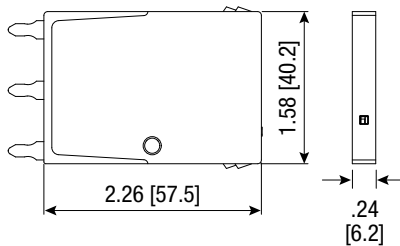

NSP-2-xxxM LF Series	24	24/0
Dimensions		
Weight per Unit	0.56 oz [16g]	0.49 oz [14g]
Packaging Dimensions (Single Unit)	4.45×4.37×0.43" [113×111×11 mm]	
Minimum Package Quantity	15 pieces	

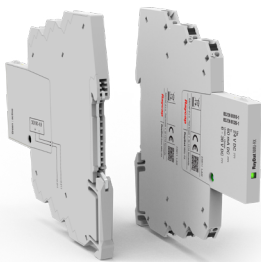

Monitoring Unit
Transmitter
& Receiver
available for all
product variants.

inches
[mm]



Modular SPD for Single Pair

RayDat NSP-2 Series

D1 • C1 • C2 • C3



IEC/EN Category: D1/C1/C2/C3
 Voltages: 24, 110 V DC
 Frequency Range: 120 MHz
 Housing: Modular Design
 Compliance: IEC/EN 61643-21
 UL 497B 4th Edition

Configuration:

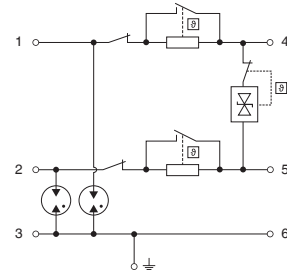

Technical Data

NSP-2 Series	24	110*
Electrical		
Lines Protected	1 (2 Conductors)	
Nominal Operating Voltage (DC)	U_n 24V	110V
Maximum Continuous Operating Voltage (DC)	U_c 30V	170V
Rated Load Current at 40 °C	I_L	800 mA
Rated Load Current at 70 °C	I_L	600 mA
C2 Nominal Discharge Current (8/20 μ s)	(Line-Line) I_n	10 kA
	(Line-Ground)	10 kA
C2 Total Nominal Discharge Current (8/20 μ s)	I_n	20 kA
C2 Voltage Protection Level (10kV/5kA)	(Line-Line) U_p	180V
	(Line-Ground)	950V
C3 Voltage Protection Level (1 kV/ μ s)	(Line-Line) U_p	70V
	(Line-Ground)	650V
D1 Impulse Current (10/350 μ s)	(Line-Line) I_{imp}	2.5 kA
	(Line-Ground)	2.5 kA
D1 Total Impulse Current (10/350 μ s)	I_{imp}	5 kA
Rated Spark Overvoltage	(Line-Line)	33V - 51V
	(Line-Ground)	184V - 286V
Response Time Overvoltage Protection	t_A	< 1 ns
Thermal Protection		Yes
Insulation Resistance of the Protection	(Line-Line) R_{iso}	> 15 M Ω
Serial Resistance per Path	R	1 Ω
Capacitance	(Line-Line) C	typ. 25 pF
	(Line-Ground)	typ. 15 pF
Maximum Frequency	f_G	120 MHz
Mechanical		
Temperature Range	-40 °F to +176 °F [-40 °C to +80 °C]	
Conductor Cross Section (max.)	12 AWG / 4 mm ² (solid)	
	14 AWG / 2.5 mm ² (flexible)	
Degree of Protection IEC/EN 60529	IP20 (built-in)	
Housing Material	Thermoplastic; Grey; Extinguishing Degree V-0	
Mounting IEC/EN 60715	35 mm DIN Rail	
Operating State / Fault Indication	Green Flag / Red Flag	
Order Information		
Order Code	24	110*
NSP-2-xx	7088.05	7088.07
NSP-2-xxM (module)	7088.06	7088.08

*No UL Certification.

RayDat NSP-2 Series

Configuration

Legend

- DB Diode Block
- GDT Gas Discharge Tube
- PG Protective Grounding
- R Resistor

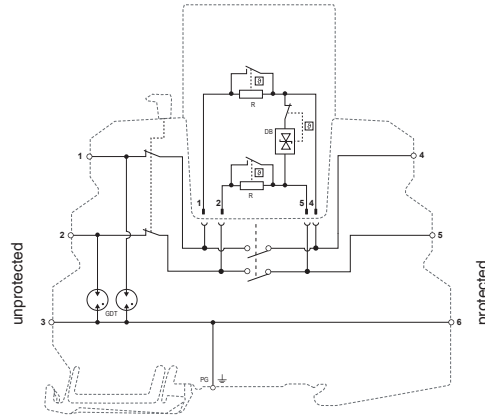

Dimensions & Packaging

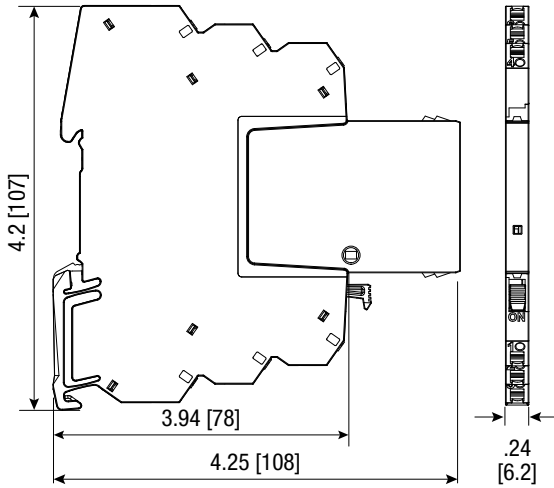

NSP-2 Series	24	110*
Dimensions		
Weight per Unit	2.12 oz [60g]	
Dimensions DIN 43880	.24" [6.2mm]	
Packaging Dimensions (Single Unit)	4.45×4.37×0.43" [113×111×11 mm]	
Minimum Package Quantity	15 pieces	

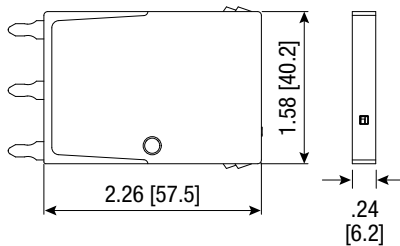

NSP-2-xxxM Series	24	110*
Dimensions		
Weight per Unit	0.56 oz [16g]	
Packaging Dimensions (Single Unit)	4.45×4.37×0.43" [113×111×11 mm]	
Minimum Package Quantity	15 pieces	

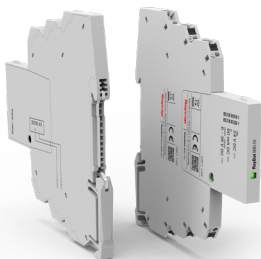

Monitoring Unit
Transmitter
& Receiver
available for all
product variants.

inches
[mm]



Notes

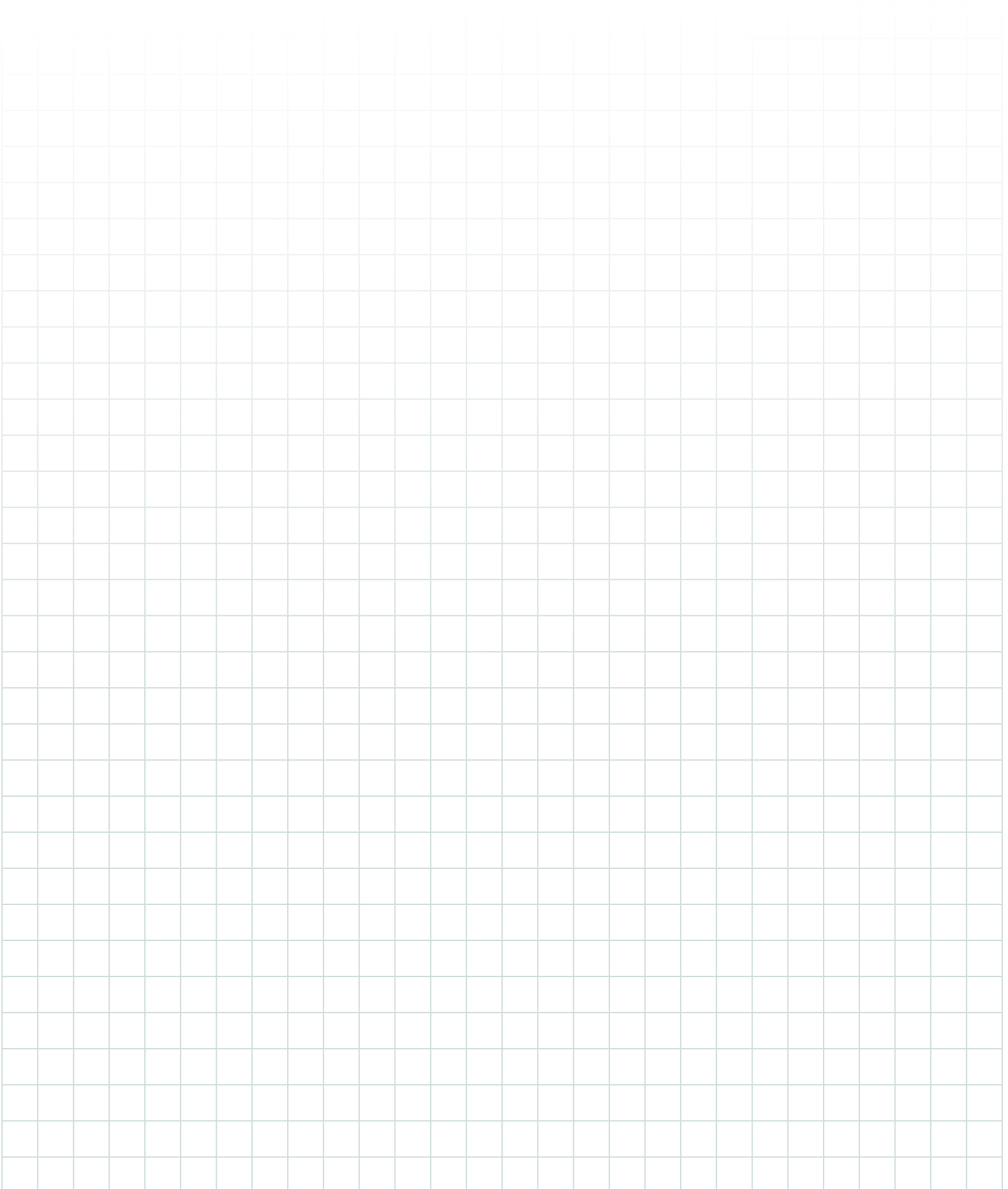

Surge Protective Devices (SPDs) for Bus Systems



Bus Systems

RayDat NSB-3 LF Series
RayDat NSB-3 Series

Special features:

- Narrow form factor - just 6.2 mm wide
- Very high surge ratings
- Different shield-handling options available
- The connection lines remain enabled during module replacement (hot swapping)
- Equipped with quick connect terminals for fast wiring

Application:

- Fieldbus systems
(CAN Bus, Profibus DP,
RS 232/V.24 m, RS 485, Sinec L2)

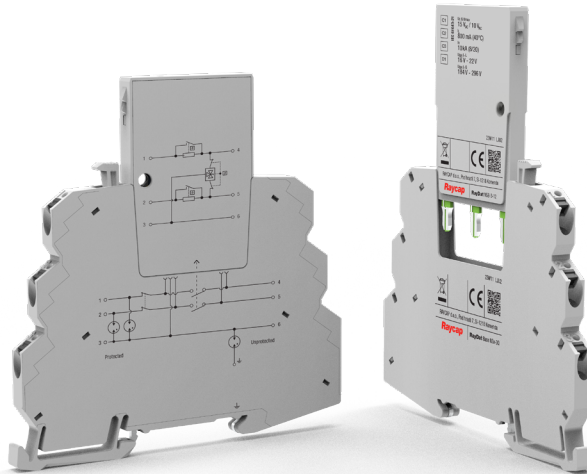

Bus systems play a pivotal role in communicating between connected equipment in modern smart homes, offices, and factories. A wide range of electronic devices use digital signals. As the reliance on digital equipment grows, so does the need to protect these critical systems from electrical overvoltage.

The RayDat NSB-3 Series of surge protective devices has been developed to protect fieldbus systems (CAN Bus, Profibus DP, RS 232/V.24 m, RS 485, Sinec L2). The products are intended for those applications where high ground potential rises may frequently occur, such as in locations close to electric railways.

Modular SPD for Industrial Fieldbus Systems

RayDat NSB-3 LF Series

D1 • C1 • C2 • C3



IEC/EN Category: D1/C1/C2/C3

Voltages: 5, 12, 24, 48 V DC

Frequency Range: up to 4 MHz

Housing: Modular Design

Compliance: IEC/EN 61643-21

UL 497B 4th Edition

Configuration:

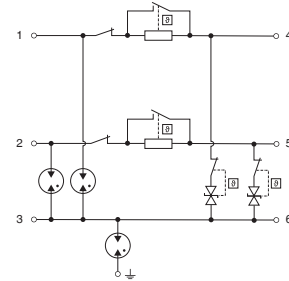

Technical Data

NSB-3 LF Series

5

12

24

Electrical

Lines Protected		5	12	24
Lines Protected			1 (3 Conductors)	
Nominal Operating Voltage (DC)	U_n	5V	12V	24V
Maximum Continuous Operating Voltage (DC)	U_c	8.5V	15V	30V
Rated Load Current at 40 °C	I_L		800 mA	
Rated Load Current at 70 °C	I_L		600 mA	
C2 Nominal Discharge Current (8/20 μ s)	(Line-Line) I_n		10 kA	
	(Line-Ground)		10 kA	
C2 Total Nominal Discharge Current (8/20 μ s)	I_n		10 kA	
C2 Voltage Protection Level (10kV/5kA)	(Line-Line) U_p	80V	100V	160V
	(Line-Ground)	1100V	1100V	1100V
C3 Voltage Protection Level (1 kV/ μ s)	(Line-Line) U_p	48V	60V	120V
	(Line-Ground)	650V	660V	680V
D1 Impulse Current (10/350 μ s)	(Line-Line) I_{imp}		2.5 kA	
	(Line-Ground)		2.5 kA	
D1 Total Impulse Current (10/350 μ s)	I_{imp}		2.5 kA	
Rated Spark Overvoltage	(Line-Line)	18V-46V	32V-62V	66V-98V
	(Line-Ground)	193V-334V	200V-354V	217V-360V
Response Time Overvoltage Protection	t_A		< 1 ns	
Thermal Protection			Yes	
Insulation Resistance of the Protection	(Line-Line) R_{iso}	> 340 k Ω	> 15 M Ω	> 30 M Ω
Serial Resistance per Path	R		1 Ω	
Capacitance	(Line-Line) C	typ. 5 nF	typ. 2 nF	typ. 0.8 nF
	(Line-Ground)	typ. 10 pF	typ. 10 pF	typ. 10 pF
Maximum Frequency	f_G	550 kHz	1.2 MHz	2 MHz

Mechanical

Temperature Range	-40 °F to +176 °F [-40 °C to +80 °C]
Conductor Cross Section (max.)	12 AWG / 4 mm ² (solid) 14 AWG / 2.5 mm ² (flexible)
Degree of Protection IEC/EN 60529	IP20 (built-in)
Housing Material	Thermoplastic; Grey; Extinguishing Degree V-0
Mounting IEC/EN 60715	35 mm DIN Rail
Operating State / Fault Indication	Green Flag / Red Flag

Order Information

Order Code	5	12	24
NSB-3-xx LF	7088.15	7088.17	7088.19
NSB-3-xxM LF (module)	7088.16	7088.18	7088.20

RayDat NSB-3 LF Series

Configuration

Legend

- BD Bi-directional TVS Diode
- GDT Gas Discharge Tube
- PG Protective Grounding
- R Resistor

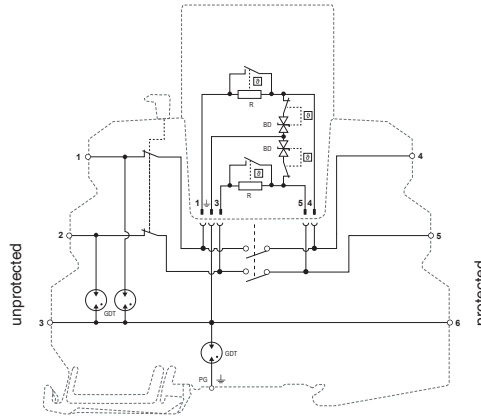

Dimensions & Packaging

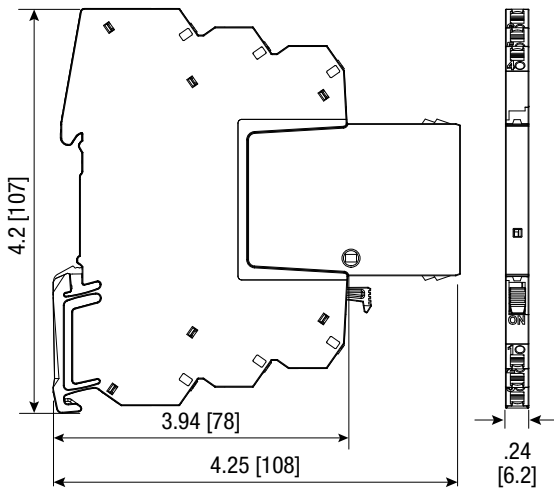

NSB-3 LF Series	5	12	24
Dimensions			
Weight per Unit	2.12 oz [60g]		
Dimensions DIN 43880	.24" [6.2mm]		
Packaging Dimensions (Single Unit)	4.45×4.37×0.43" [113×111×11 mm]		
Minimum Package Quantity	15 pieces		

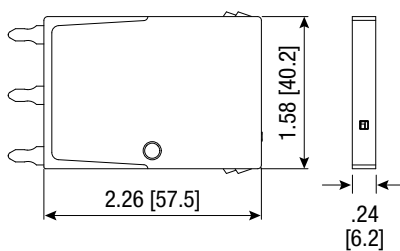

NSB-3-xxxM LF Series	5	12	24
Dimensions			
Weight per Unit	0.56 oz [16g]		
Packaging Dimensions (Single Unit)	4.45×4.37×0.43" [113×111×11 mm]		
Minimum Package Quantity	15 pieces		

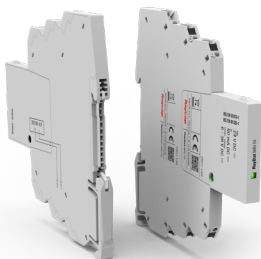

Monitoring Unit
Transmitter
& Receiver
available for all
product variants.

inches
[mm]



RayDat NSB-3 Series

Configuration

Legend

- DB Diode Block
- GDT Gas Discharge Tube
- PG Protective Grounding
- R Resistor

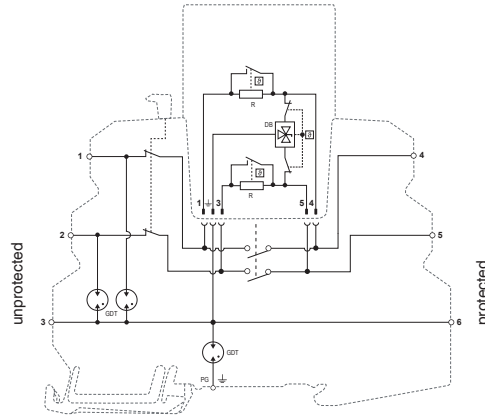

Dimensions & Packaging

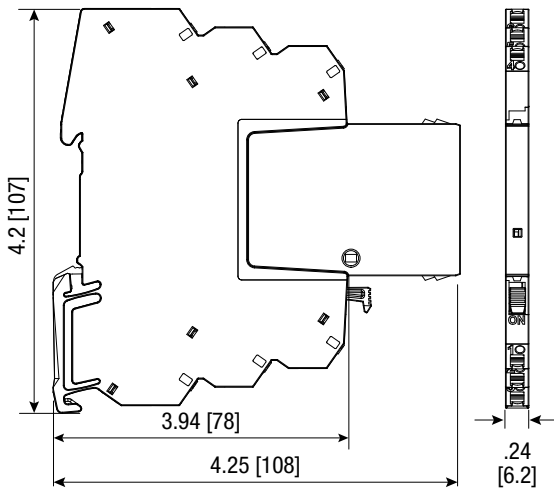

NSB-3 Series	5	12	24	48
Dimensions				
Weight per Unit	2.12 oz [60g]			
Dimensions DIN 43880	.24" [6.2 mm]			
Packaging Dimensions (Single Unit)	4.45×4.37×0.43" [113×111×11 mm]			
Minimum Package Quantity	15 pieces			

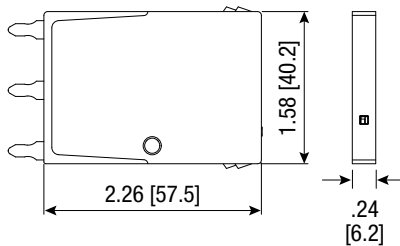

NSB-3-xxxM Series	5	12	24	48
Dimensions				
Weight per Unit	0.56 oz [16g]			
Packaging Dimensions (Single Unit)	4.45×4.37×0.43" [113×111×11 mm]			
Minimum Package Quantity	15 pieces			



Monitoring Unit
Transmitter
& Receiver
available for all
product variants.

inches
[mm]



Notes

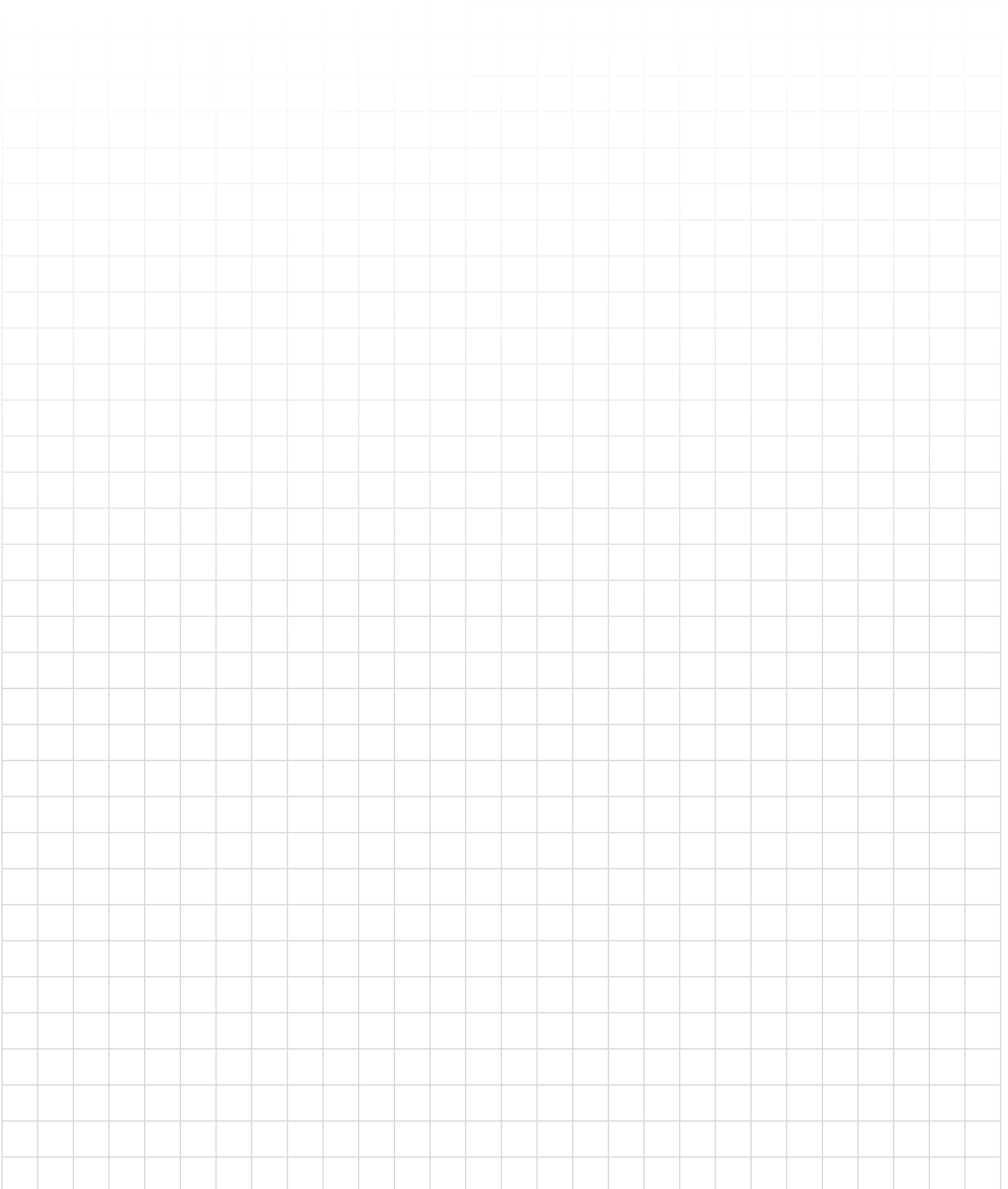

Modular Surge Protective Devices (SPDs)
for DC Power Systems in Signaling Applications

DC Power Systems for Signaling Applications

RayDat NPS-2 Series

Special features:

- Narrow form factor - just 6.2 mm wide
- High surge ratings
- Suitable for AC and DC power systems
- The connection lines remain enabled during module replacement (hot swapping)
- Equipped with quick connect terminals for fast wiring

Application:

- PoE - Power supplying lines used for Power over Ethernet signal lines and powerful signal lines

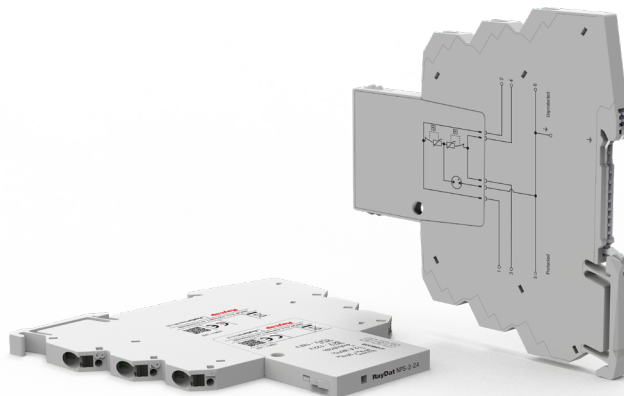

The RayDat Narrow Line series protects DC power lines in protocols that require the protection of both power and signal lines, such as the CAN bus and DeviceNet.

The RayDat NPS-2 Series is designed to protect power supplies. Protection is provided by a combination of gas discharge tube (GDT) and metal oxide varistor (MOV) technologies.

SPD for DC Power Systems

RayDat NPS-2 Series

C1 • C2 • C3

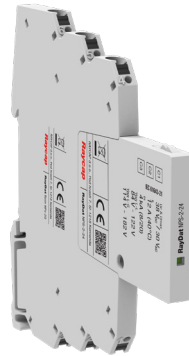

IEC/EN Category: C1/C2/C3
 Voltages: 24, 48 V DC
 Frequency Range: up to 800 kHz
 Housing: Modular Design
 Compliance: IEC/EN 61643-21
 UL 497B 4th Edition

Configuration:

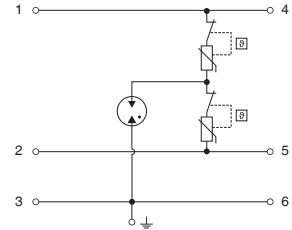

Technical Data

NPS-2 Series

24

Electrical

Lines Protected		1 (2 Conductors)
Nominal Operating Voltage (DC)	U_n	24V
Maximum Continuous Operating Voltage (DC)	U_c	38V
Maximum Continuous Operating Voltage (AC)	U_c	38V
Rated Load Current at 40 °C	I_L	12A
Rated Load Current at 70 °C	I_L	10A
C2 Nominal Discharge Current (8/20 μ s)	(Line-Line) I_n	4 kV/2 kA
	(Line-Ground)	4 kV/2 kA
C2 Total Nominal Discharge Current (8/20 μ s)	I_n	8 kV/4 kA
C2 Voltage Protection Level (4 kV/2 kA)	(Line-Line) U_p	250V
	(Line-Ground)	650V
C3 Voltage Protection Level (1 kV/ μ s)	(Line-Line) U_p	200V
	(Line-Ground)	700V
Rated Spark Overvoltage	(Line-Line)	84V - 106V
	(Line-Ground)	72V - 160V
Response Time Overvoltage Protection	t_A	<25 ns
Thermal Protection		Yes
Insulation Resistance of the Protection	(Line-Line) R_{iso}	> 10 M Ω
Serial Resistance per Path	R	0.1 Ω
Capacitance	(Line-Line) C	typ. 5 nF
	(Line-Ground)	typ. 10 pF
Maximum Frequency	f_G	550 kHz

Mechanical

Temperature Range	-40 °F to +176 °F [-40 °C to +80 °C]
Conductor Cross Section (max.)	12 AWG / 4 mm ² (solid)
	14 AWG / 2.5 mm ² (flexible)
Degree of Protection IEC/EN 60529	IP 20 (built-in)
Housing Material	Thermoplastic; Grey; Extinguishing Degree V-0
Mounting IEC/EN 60715	35 mm DIN Rail
Operating State / Fault Indication	Green Flag / Red Flag

Order Information

Order Code	24
NPS-2-xx	7088.21
NPS-2-xxM (module)	7088.22

RayDat NPS-2 Series

Configuration

Legend

- GDT Gas Discharge Tube
- PG Protective Grounding
- MOV Metal Oxide Varistor

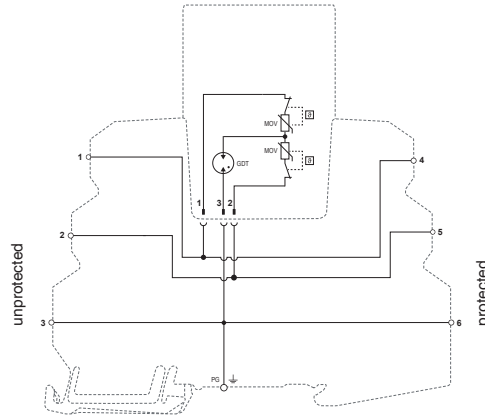

Dimensions & Packaging

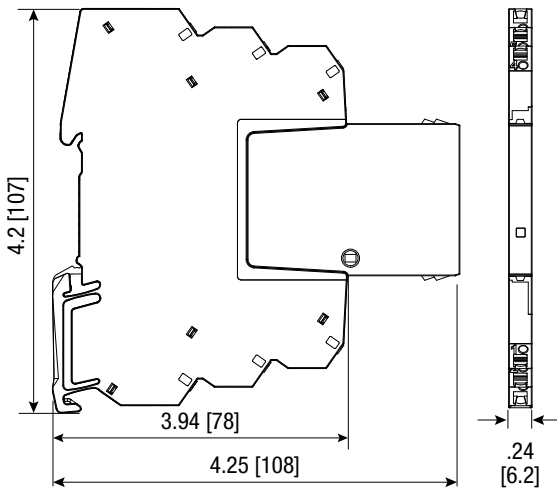

NPS-2 Series	24
Dimensions	
Weight per Unit	2.05 oz [58g]
Dimensions DIN 43880	.24" [6.2mm]
Packaging Dimensions (Single Unit)	4.45×4.37×0.43" [113×111×11 mm]
Minimum Package Quantity	15 pieces

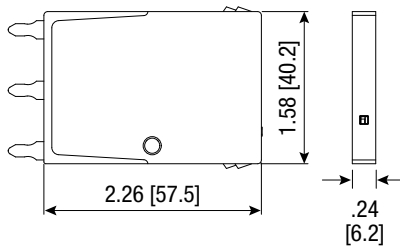

NPS-2-xxxM Series	24
Dimensions	
Weight per Unit	0.56 oz [16g]
Packaging Dimensions (Single Unit)	4.45×4.37×0.43" [113×111×11 mm]
Minimum Package Quantity	15 pieces



Monitoring Unit
Transmitter
& Receiver
available for all
product variants.

inches
[mm]

Notes

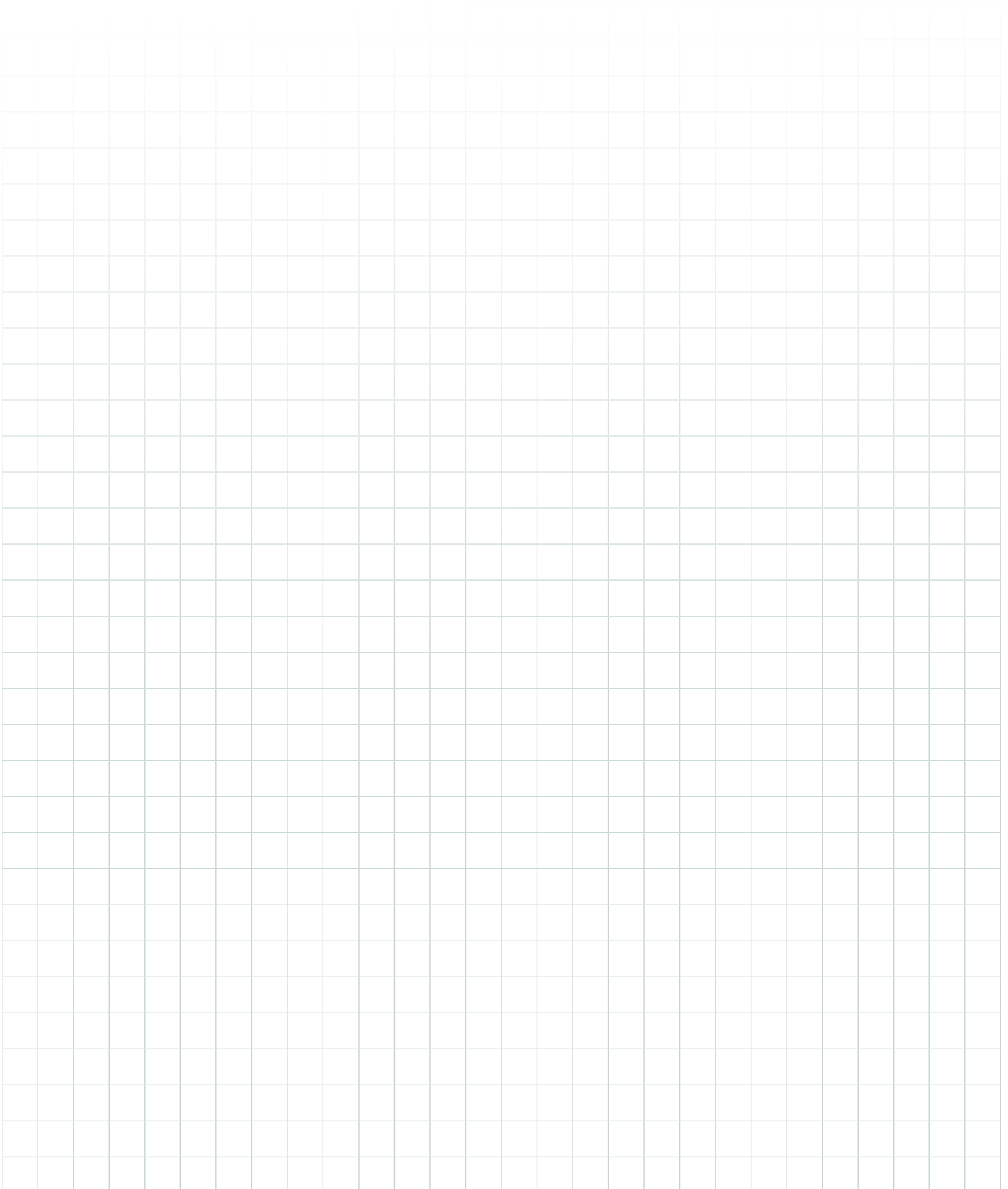

Monitoring Units for Surge Protective Devices (SPDs)



Monitoring Units

RayDat NMU Set
RayDat NMU-TX
RayDat NMU-RX

Special features:

- Narrow form factor - just 6.2 mm wide
- Up to 50 SPDs can be monitored with a pair of NMUs
- SPD failures are monitored by the receiving unit
- Each SPD has its own LED indicator for quick identification of any defect
- Used in systems ranging from 6-36V DC
- Equipped with quick connect terminals for fast wiring



When placed on either end of a Narrow Line stack, the Monitoring Transmitter Unit (NMU-TX) & Receiver Unit (NMU-RX) will check the status of up to 50 surge protective devices in a row.

The monitoring devices have built-in LED indicators. To monitor the status of each SPD, the Transmitter Unit emits a directional light beam that travels through the individual products to the Receiver Unit.

Monitoring Unit RayDat NMU Series

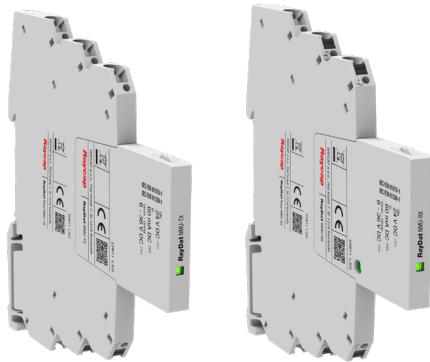

Voltages: 6-36 V DC System
Housing: Modular Design
Compliance: IEC/EN 61010-1
IEC/EN 61326-1
UL 497B 4th Edition

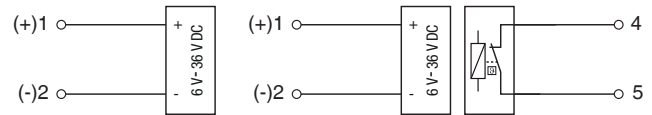

RayDat NMU-TX Series

RayDat NMU-RX Series

Technical Data

NMU-TX Series

Electrical

Maximum Number of Controlled SPDs		up to 50
Operation Voltage	$U_{\min} - U_{\max}$	6 - 36V DC
Nominal Voltage	U_N	24V DC
Operating Current	I	60mA DC

NMU-RX Series

Electrical

Maximum Number of Controlled SPDs		up to 50
Operation Voltage	$U_{\min} - U_{\max}$	6 - 36V DC
Nominal Voltage	U_N	24V DC
Operating Current	I	60mA DC
Output (Remote Contact)	(Line 2-4)	max 50V DC, max. 500mA DC

Mechanical

Temperature Range		-40 °F to +176 °F [-40 °C to +80 °C]
Conductor Cross Section (max.)		12 AWG / 4 mm ² (solid) 14 AWG / 2.5 mm ² (flexible)
Degree of Protection IEC/EN 60529		IP20 (built-in)
Housing Material		Thermoplastic; Grey; Extinguishing Degree V-0
Mounting IEC/EN 60715		35mm DIN Rail
Operating State / Fault Indication (NMU-RX)		Green LED / Red LED / RC Contact
Operating State (NMU-TX)		Green LED

Order Information

Order Code		
NMU Set (Monitoring Unit Set, Transmitter & Receiver)		7088.23
NMU-TX (Monitoring Unit Transmitter)		7088.24
NMU-RX (Monitoring Unit Receiver)		7088.25

RayDat NMU Series

Configuration

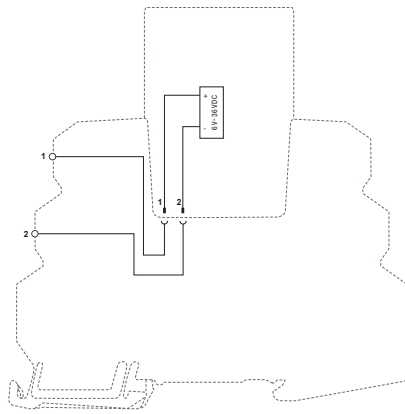

RayDat NMU-TX Series

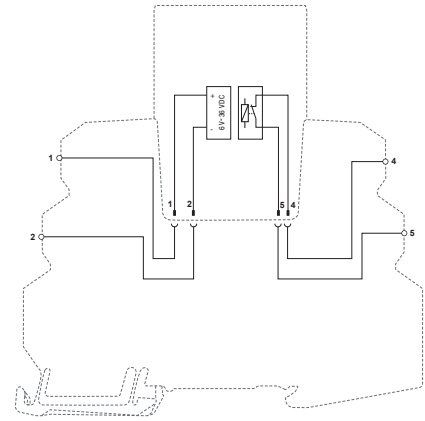

RayDat NMU-RX Series

Dimensions & Packaging

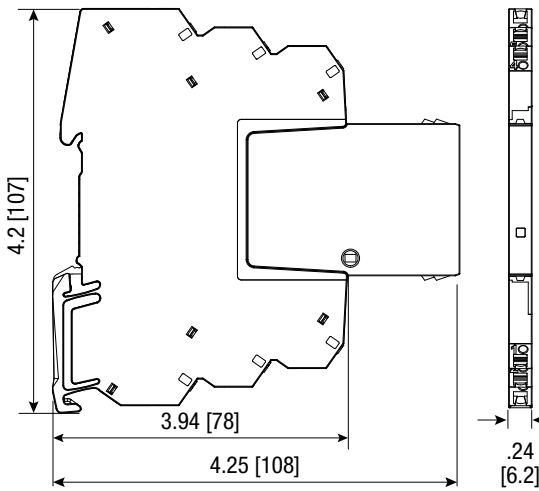

NMU Set (NMU TX & NMU RX)

Dimensions	
Weight per Unit	3.60 oz [102 g]
Dimensions DIN 43880	.24" [6.2 mm]
Packaging Dimensions (Single Unit)	4.45 × 4.37 × 0.73" [113 × 111 × 18.5 mm]
Minimum Package Quantity	9 pieces

NMU-TX Series

Dimensions	
Weight per Unit	1.76 oz [50 g]
Dimensions DIN 43880	.24" [6.2 mm]
Packaging Dimensions (Single Unit)	4.45 × 4.37 × 0.43" [113 × 111 × 11 mm]
Minimum Package Quantity	15 pieces

NMU-RX Series

Dimensions	
Weight per Unit	1.83 oz [52 g]
Dimensions DIN 43880	.24" [6.2 mm]
Packaging Dimensions (Single Unit)	4.45 × 4.37 × 0.43" [113 × 111 × 11 mm]
Minimum Package Quantity	15 pieces

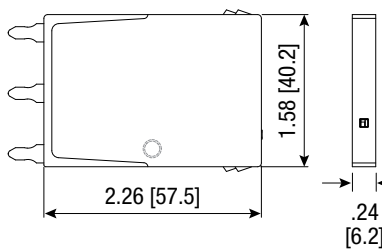

NMU-TXM Series

Dimensions	
Weight per Unit	0.49 oz [14 g]
Packaging Dimensions (Single Unit)	4.45 × 4.37 × 0.43" [113 × 111 × 11 mm]
Minimum Package Quantity	15 pieces

NMU-RXM Series

Dimensions	
Weight per Unit	0.49 oz [14 g]
Packaging Dimensions (Single Unit)	4.45 × 4.37 × 0.43" [113 × 111 × 11 mm]
Minimum Package Quantity	15 pieces

inches
[mm]

Notes

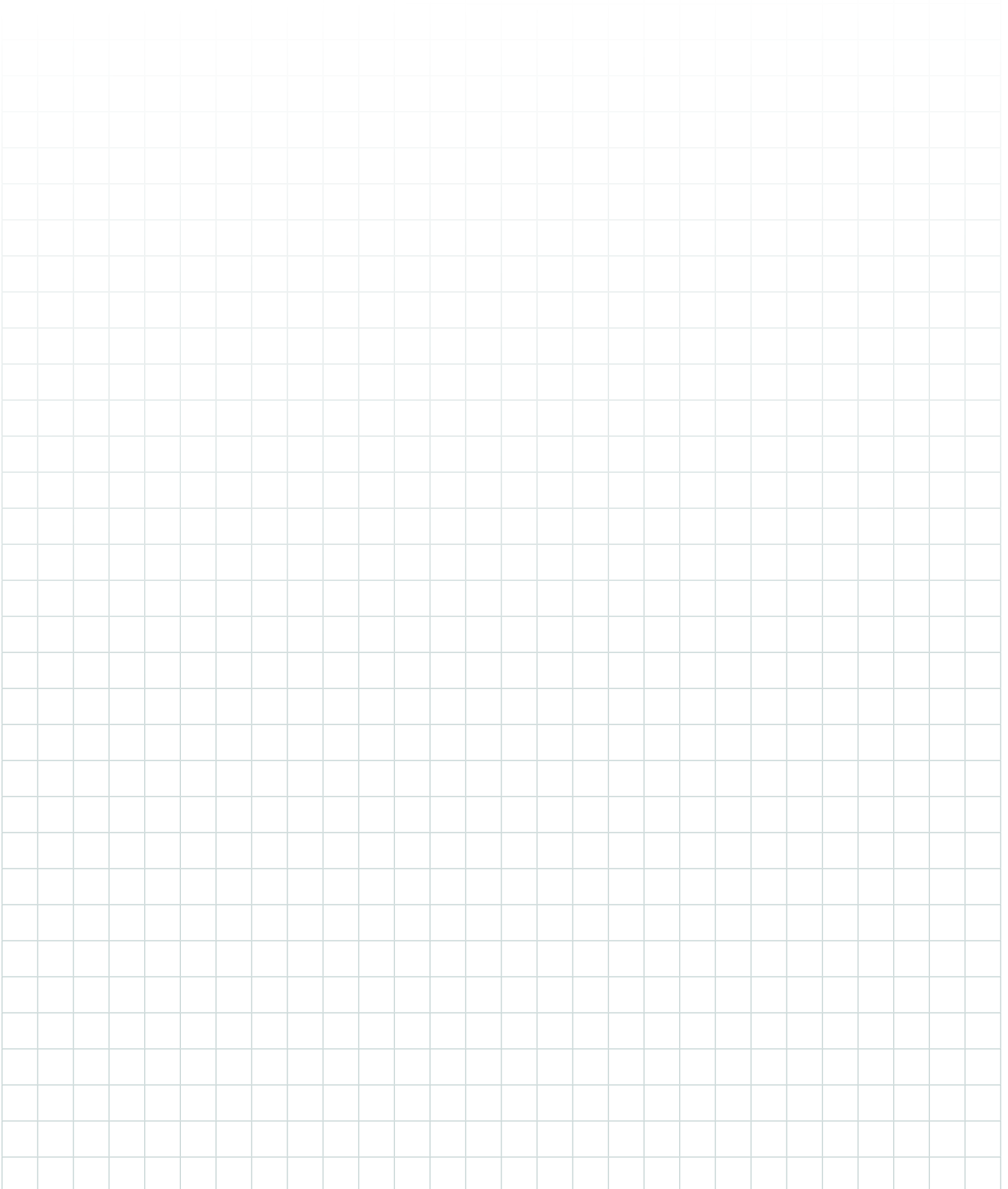

Product Index

	New Product Name	New Order Code	Legacy Product Names & Order Codes		Page
			Product	Order Code	
Analog Systems Modular SPD for Data & Signal Lines					
	RayDat NSL-2-5 LF	7088.32			8
	RayDat NSL-2-12 LF	7088.34			8
	RayDat NSL-2-24 LF	7088.36			8
	RayDat NSL-2-5M LF	7088.33			8
	RayDat NSL-2-5M LF	7088.35			8
	RayDat NSL-2-5M LF	7088.37			8
	RayDat NSL-2-5	7088.26	RayDat SLH-2-5Q	7085.05	10
	RayDat NSL-2-12	7088.28	RayDat SLH-2-12Q	7085.06	10
	RayDat NSL-2-24	7088.01	RayDat SLH-2-24Q	7085.08	10
	RayDat NSL-2-48	7088.30	RayDat SLH-2-48Q	7085.10	10
	RayDat NSL-2-5M	7088.27	RayDat SLH-2-5M	7086.40	10
	RayDat NSL-2-12M	7088.29	RayDat SLH-2-12M	7086.41	10
	RayDat NSL-2-24M	7088.02	Module SLH-2-24M	7086.43	10
	RayDat NSL-2-48M	7088.31	RayDat SLH-2-48M	7086.44	10
	RayDat NSP-2-24 LF	7088.03			14
	RayDat NSP-2-24/0 LF	7088.60			14
	RayDat NSP-2-24M LF	7088.04			14
	RayDat NSP-2-24/0M LF	7088.61			14
	RayDat NSP-2-24	7088.05	RayDat SPH-2-30Q	7085.25	16
	RayDat NSP-2-110	7088.07			16
	RayDat NSP-2-24M	7088.06	Module SPH-2-30M	7082.85	16
	RayDat NSP-2-110M	7088.08			16
Digital Systems Modular SPD for Data & Signal Lines					
	RayDat NSB-3-5 LF	7088.15			20
	RayDat NSB-3-12 LF	7088.17			20
	RayDat NSB-3-24 LF	7088.19			20
	RayDat NSB-3-5 LFM	7088.16			20
	RayDat NSB-3-12 LFM	7088.18			20
	RayDat NSB-3-24 LFM	7088.20			20
	RayDat NSB-3-5	7088.09	RayDat SBH-3-5Q	7085.21	22
	RayDat NSB-3-12	7088.11	RayDat SBH-3-12Q	7085.22	22
	RayDat NSB-3-24	7088.13	RayDat SBH-3-30Q	7085.23	22
	RayDat NSB-3-48	7088.54			22
	RayDat NSB-3-5M	7088.10	RayDat SBH-3-5M	7082.87	22
	RayDat NSB-3-12M	7088.12	RayDat SBH-3-12M	7082.89	22
	RayDat NSB-3-24M	7088.14	RayDat SBH-3-30M	7082.91	22
	RayDat NSB-3-48M	7088.55			22
Modular SPD for DC Power Systems in Signaling Applications					
	RayDat NPS-2-24	7088.21	RayDat PSC-2-24	7086.84	26
	RayDat NPS-2-24M	7088.22	Module PSC-2-24M	7086.87	26
Monitoring Unit Transmitter & Receiver					
	RayDat NMU Set	7088.23			30
	RayDat NMU-TX	7088.24			30
	RayDat NMU-RX	7088.25			30



Raycap reserves the right to introduce changes in performance, dimensions and materials in the course of technical progress. No part of this work, nor of the information laid down herein and or derivable here from and/ or developed in connection here with, may be reproduced or used in any form or by any means. Legal action will be taken against infringements. This publication replaces previous editions and is subject to change at any time.

©2024 Raycap All rights reserved.

Raycap Worldwide Locations



Raycap Inc.
806 South Clearwater Loop
Post Falls, ID 83854
United States of America

7555-A Palmetto Commerce Pkwy
North Charleston, SC 29420
United States of America

46 Sellers Street
Kearny, NJ 07032
United States of America

Raycap GmbH
Parkring 11
85748 Garching Munich
Germany

Raycap S.A.
Telou & Petroutsou 14
15124 Maroussi Athens
Greece

Raycap S.A. Manufacturing
Industrial Area of Drama
66100 Drama
Greece

Raycap d.o.o.
Poslovna cona Žeje pri Komendi
Pod hrasti 7
1218 Komenda
Slovenia

Raycap Cyprus Ltd.
46 Lefkosias Street
Industrial Area of Dali
2540 Nicosia
Cyprus

Raycap SAS
84 rue Charles Michels
Building B
93200 Saint-Denis
France

Raycap Corporation SRL
102, Barbu Vacarescu
entrance D, 4th floor, D22,
020283 Bucharest
Romania

Raycap (Suzhou) Co. Ltd.
Block B, Phase II
of New Sea Union
No. 58 Heshun Road
SIP, Suzhou 215122
Jiangsu Province
China



Raycap

raycap.com info@raycap.com

© 2024 Raycap All rights reserved.
G29-01-576 241003